

SEV INSTALLATION INSTRUCTIONS

FOR HVAC RETRO-FITS

Introduction

The SEV is an electrically actuated, fast acting proportional expansion valve, designed for use in multiple refrigerants including R410a, R404a, R134a, and R-22. It features a silicon microvalve piloting a spool that acts independently of suction line pressure. The main flow path is controlled by the spool, which in turn is controlled by the pilot valve. The pilot valve applies varying fractions of the liquid line pressure to the spool according to the command signal, such that the spool follows the fractional opening of the pilot. The pilot is actuated using a 24V PWM command signal. The applied voltage creates localized thermal expansion in the resistive elements inside the valve, which is then converted to linear motion resulting in valve actuation. The valve is controlled by the Microstaq Superheat Controller (SHC), which is attached at the exit of the evaporator using a standard 1/4" Schrader connection. The SHC (provided) measures suction pressure and temperature, calculates superheat, and transmits the appropriate command to the valve. The SHC cable (provided) includes the necessary temperature sensor, power input, power output cable (to valve), and communications cable to operate the valve.

Valve Installation

The SEV is an electronically controlled expansion valve, and the installation is very similar to that of a conventional TXV. The SEV is to be installed at the entrance of the evaporator, in place of the TXV. (The SHC is to be installed at the exit of the evaporator, in place of the TXV bulb, with the provided SHC cable connecting the two.)

1. Properly reduce system pressure to atmospheric conditions (pumpdown).
2. Remove TXV and bulb, by either cutting or brazing. If brazing, remove any nearby Schrader cores.
3. Position the SEV to ensure proper orientation and flow direction (See Figure 1). The SEV allows flow in ONE DIRECTION ONLY, so it is critical the valve is installed in the correct direction. The SEV can be installed horizontally or vertically, but should not be installed with the pilot (top) facing downward or at a downward angle.

4. Ensure the cleanliness of the copper connections before brazing. The SEV comes standard with 3/8" copper tube extensions, each 3" in length. Additional fittings may be required to accommodate the desired application. If possible, avoid cutting down the length of the extensions.
5. **Before brazing, wrap the valve body in a wet cloth. While brazing, direct heat away from the valve body. The valve body must not exceed 300°F during installation.** Allow the valve to air cool after brazing.

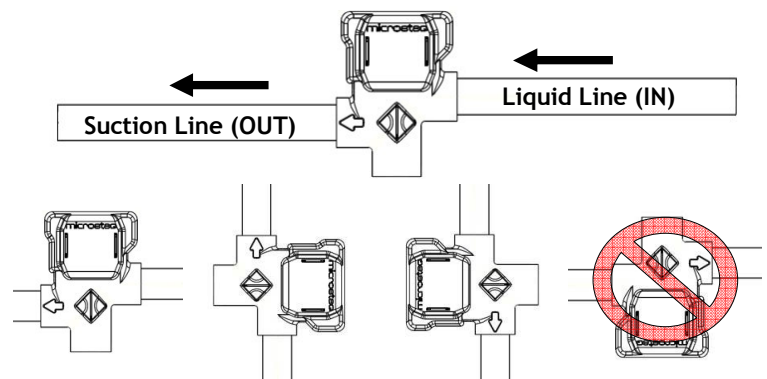

Figure 1: SEV Installation Orientation

Controller and Wiring Installation

The SHC mounts on a standard 1/4" Schrader port at the exit of the evaporator in the same general location that a TXV bulb is typically installed.

1. If required, braze in necessary Schrader ports. In most applications, there will already be an adequate port to install the SHC, however, certain applications may not have an adequate port for installation. Ideally, the installation port should be located on the suction line directly after the evaporator, however almost any suction side port is acceptable provided it is within reach of the SHC cable thermistor to the evaporator exit. After brazing replace any removed Schrader cores.
2. Install the SHC on the Schrader port. It is recommended the SHC be installed to the side or at an angle to allow condensation to fall away from the device. You may use the SHC housing for the first few turns on the Schrader, but **DO NOT TIGHTEN THE SHC USING THE HOUSING**. As soon as there is resistance, use a 9/16" wrench on the hex nut at the bottom of the SHC (See Figure 2) to complete the installation.
3. Attach the SHC Cable to the SHC and install the thermistor. (Figures 2, 4 & 5). The SHC cable includes a large Molex connector that fits into the SHC, and a thermistor, which should be wire tied to the evaporator suction line and wrapped with insulated tape (See Figure 5). Attach the thermistor to a flat length of the suction line as close as possible to the evaporator exit.

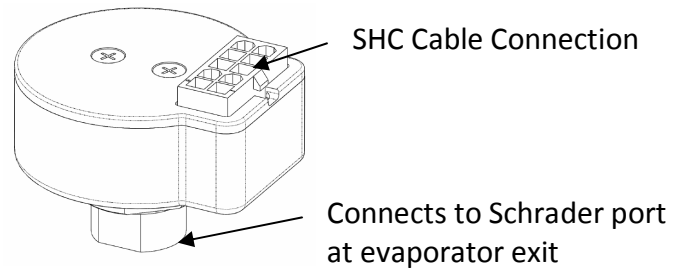

Figure 2: Superheat Controller

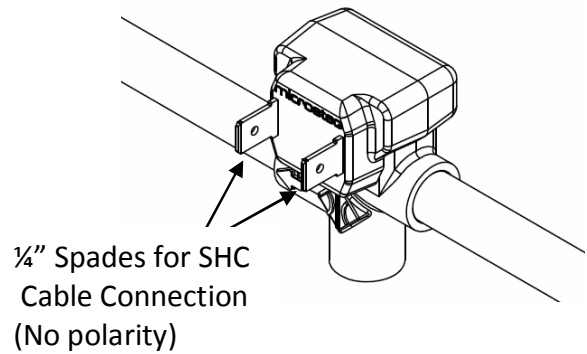

Figure 3: SEV Electrical Connections

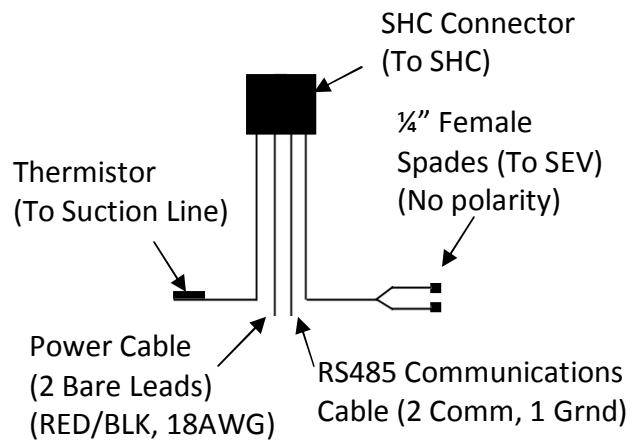

Figure 4: SHC Cable Diagram

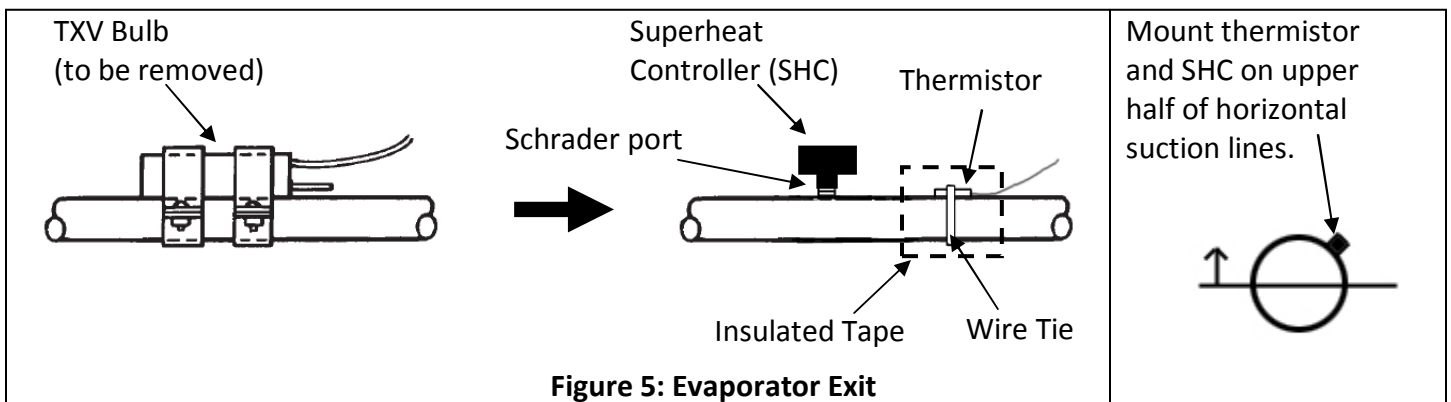

Figure 5: Evaporator Exit

4. The SHC power cables (18 AWG red/black cables, bare leads) will need to be connected to a 24 VAC source. In nearly all cases, there will be a 24V transformer mounted in the control box of the indoor AC unit (evaporator). The transformer will likely be labeled to identify the secondary voltage terminals (See Figure 6). To be certain, check the voltage of the transformer with a multimeter to verify which side is the secondary coil. The reading should be at or near 24VAC. It is not uncommon for the voltage to be slightly higher than 24V, but should not exceed 30V.
5. Once the secondary side of the transformer has been identified and checked, **shut off power to the system**, check again (with multimeter) to ensure power is off, and connect the SHC power cables (18 AWG red/black cables). Connect one cable to each of the two secondary transformer terminals (Figure 6). There is no polarity with the SHC, so the cable order doesn't matter and the colors have no significance. Typically, the transformers will have a ¼" male spade terminal for connection, which will likely be occupied. It may be necessary to install a double female spade (or other termination) to add the SHC cable to the secondary terminals. If the SHC cables do not reach the system transformer, it will be necessary to add extensions to the cables. 18 AWG stranded copper wire is recommended for power cable extensions. Use appropriate connections/insulation to prevent water infiltration. It is recommended that dielectric grease-filled wire nuts or insulated mating connectors are used for all power interconnects.
6. Restore electrical power to the system. Restore or add refrigerant to the system.
7. Connect the SHC cable to the SEV. There are two wires on the SHC cable assembly that are already fitted with insulated ¼" female spade connectors. Once system power is back on, connect these to the two ¼" male spades on the SEV (Figure 3). There is no polarity in the SHC/SEV connection.

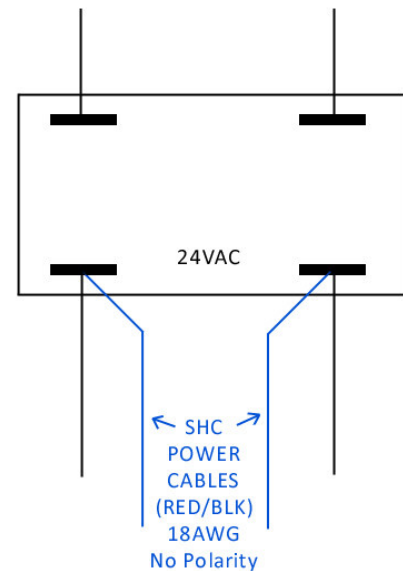

Figure 6: System Transformer

8. The only remaining unconnected cables should be a 2-wire RS485 data line (small GA. red/black) and the data ground line (green). These are the communications cables and can be left as is, but will need to be wire tied to an existing structure. Allow 6" of free cable length past the last wire tie.
9. All loose or dangling wires should be wire tied to existing structures in a neat workmanlike manner. Ensure all cables are clear of fans and potential water submersion. Ensure any bare cable leads do not touch metal structures or each other.
10. Restart the unit and check for leaks at the SHC/Schrader and all braze joints. The SHC will automatically begin controlling the SEV upon startup.