

Superheat Controller

DATASHEET



OVERVIEW

The Microstaq Superheat Controller (SHC) is a device that is used to drive and control a Silicon Expansion Valve (SEV). The hardware includes temperature and pressure sensors, while the software is adaptable to the system.

Compatible with energy management systems, the SHC functions to control superheat. The SHC provides a cost-effective solution for improved reliability, performance, and efficiency in air conditioning and refrigeration systems.

The sensing and communication capabilities of the SHC can be used to adjust flow through a SEV so that users can maintain desired system superheat conditions.

BENEFITS

Microstaq's technology and product capability align well with the global trends in HVAC and refrigeration, allowing manufacturers and retailers to provide more energy efficient systems, lower maintenance, improved compressor reliability, increased capacity, and communication. The Microstaq SHC reemphasizes Microstaq's drive for innovation in the HVAC and refrigeration sector. The SHC offers exceptional benefits and features to users, combining reliability, system savings, efficiency, and performance.

RELIABILITY

- ◆ The SHC communicates with a SEV to control temperature for HVAC and refrigeration systems. The software ensures stable super heat and prevents alarms and flooding.
- ◆ User can set SHC parameters from a computer using a RS485 interface
- ◆ With its adaptable controls, the SHC provides a platform for integrated diagnostic and communication capabilities, allowing easier service and repair

SYSTEM SAVINGS

- ◆ The SHC offers simplified electronic control to enable uncomplicated operation of the SEV
- ◆ The SHC's fault detection capability is designed to prevent extensive system damage in the event of control loop failure

EFFICIENCY AND PERFORMANCE

- ◆ Users can program the SHC to command any desired opening of the expansion valve in response to system triggers. This results in optimum efficiency and increased system performance
- ◆ The software manages the SEV in all three different stages of an air-conditioning duty cycle: start-up, steady-state, and shut down
- ◆ The control signal is directly proportional to the valve opening. Hence, the position of the valve is known at all times, allowing precise and easier tuning and control
- ◆ The SHC controls the SEV using temperature and pressure data from sensors, to provide closed-loop feedback. It also provides instantaneous, electronic superheat calculation with a 250ms response time enabling more precise super heat management
- ◆ The SHC enables better control over refrigerant flow, optimizing system performance

FEATURES

- ◆ Adaptable software versions to support a range of applications
- ◆ Pressure and Temperature Sensing ability
- ◆ Easy adjustments
- ◆ Fault Detection including sensor faults, high/low superheat, low refrigerant charge
- ◆ Serial Communication Capacity
- ◆ System energy efficiency improvement
- ◆ Cost reduction through evaporator, condenser
- ◆ Refrigerant charge reduction capability

SPECIFICATIONS

Compatible Refrigerants	R410A; R22; R404A; R134A
Compatible Oils	Polyolester; Alkylbenzene, mineral
Functions	Measurement of temperature , pressure, and calculation of superheat Maintenance of set point within $\pm 2^{\circ}\text{F}$
Maximum Working Pressure	675 psig
Life Expectancy	10 years

TECHNICAL DATA

Supply Voltage	12 VDC +/- 15%; 24V +/- 15%	
Digital Input	RS485, half-duplex, isolated supply	
Power Consumption	Idle ~ 500mW	Operating 14W
Plug-in Connector Size	10-pin moisture resistant connector, Tyco p/n 1-770858-0. 22 mm L x 10 mm W. Nine-wire harness is provided with the SHC	
Marking	Serial number label on the housing body	
Temperature	Storage -40 to 105C	Operating -40C to 80C
Humidity	0 – 80%	
Weight	75g	
Mounting	Schrader valve port, 7/16"-20, 45 degree SAE	

INPUT/OUTPUT

Temperature Input	-40-85C
Pressure Sensor Input	-1: 20-260psia (low-temp applications) -2: 45-270 psia (all other applications)
Analog Output	24VDC, 12VDC, or 24VAC, pulse-width-modulated (PWM): 0-95%
Digital Input	Operator control via Windows GUI (optional) over a half-duplex RS485 link

WIRING DIAGRAM

10 Pin Connector - Pin Assigment

- 1-Red (18 AWG) – Power Input
- 2-Black (18 AWG) – Power Input
- 4-White (18 AWG) – SEV Control
- 6-White (18 AWG) – SEV Control
- 7-Red comm. wire Shielded – RS485 +
- 5-Black comm. wire Shielded – RS485 -
- 3-green (ground signal)
- 8-thermistor (power)
- 3-thermistor (ground signal)
- 9-Spare Pin
- 10-Spare Pin

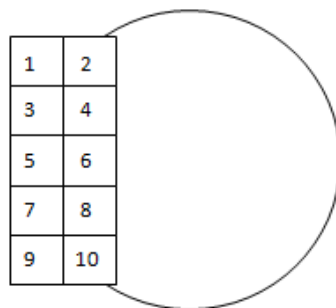

SHC PARTS

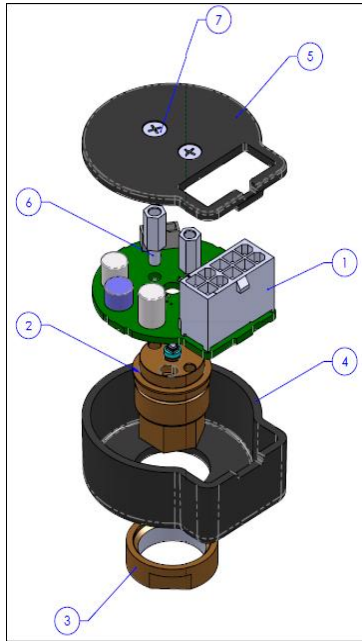

Label No.	Description	Description 2	Qty.
1	PCB ASSEMBLY	10 PIN, REVG	1
2	CORE, ABS SENSOR, ASM	SHC, REVG1	1
3	RETAINER	SUPERHEAT CONTROLLER	1
4	SHELL, SHC	REVG1	1
5	COVER, 10 PIN	SHC, REVG1	1
6	M/F HEX STANDOFF	3/16 X 11/32 X 4-40	2
7	SCREW, PHILIPS FLAT HEAD	#4-40 x 0.25 ZINC	2

PHYSICAL DIMENSIONS

Physical Dimensions	48 mm L x 42.9 mm W x 36.2 mm H
---------------------	---------------------------------

